



3544

LINEAR INTEGRATED CIRCUIT

HEADPHONE AMPLIFIER FOR CD-ROMS

DESCRIPTION

As a dual headphone amplifier the UTC **3544** is digital-source. The UTC **3544** has a steady gain of 6dB and so it is unnecessary for external gain setting. The UTC **3544** has internal mute function so that it is greatly simplified for prevention of the popping sound when power is turned on and off. To prevent damage from short circuits the UTC **3544** is equipped with thermal shutdown circuit.

FEATURES

- * Internal mute function to prevent popping sounds when the power is turned on and off.
- * Built-in thermal shutdown circuit (150°C) to prevent damage to the IC if a short circuit occurs.

ORDERING INFORMATION

Ordering Number		Package	Packing
Lead Free	Halogen Free		
3544L-D08-T	3544G-D08-T	DIP-8	Tube
3544L-S08-R	3544G-S08-R	SOP-8	Tape Reel

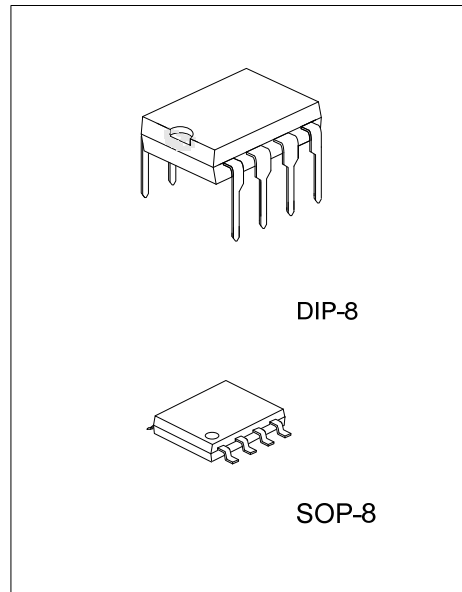

<p>3544L-D08-T</p> <p>(1) Packing Type</p> <p>(2) Package Type</p> <p>(3) Lead Plating</p>	<p>(1) T: Tube, R: Tape Reel</p> <p>(2) D08: DIP-8, S08: SOP-8</p> <p>(3) G: Halogen Free, L: Lead Free</p>
--	---

■ PIN DESCRIPTIONS

PIN NO.	PIN NAME	I/O	PIN VOLTAGE	INTERNAL EQUIVALENT CIRCUIT	FUNCTION
1 7	OUT1 OUT2	O O	2.1V 2.1V (V _{CC} =5V)		Output pin
2	MUTE	I	0.1V (When open)		Mute control pin (set to low for prevention of popping noise when power is turned on and off). Operating: High Muting: Low(open)
3 5	IN1 IN2	I I	2.1V 2.1V (V _{CC} =5V)		Input pin
6	BIAS	I/O	2.1V (V _{CC} =5V)		Bias pin (the external 47µF capacitor also serves as the anti-pop time constant, therefore make the proper considerations be changing it).
4	GND	I			
8	V _{CC}	I			

■ BLOCK DIAGRAM

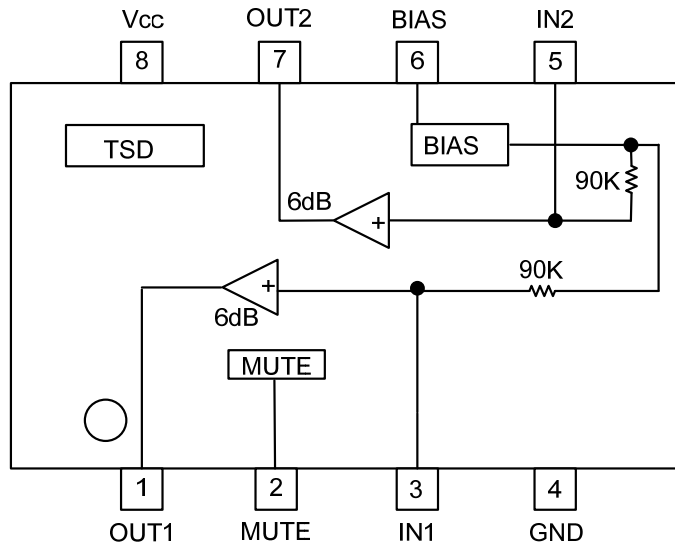

■ ABSOLUTE MAXIMUM RATINGS (Ta=25°C)

PARAMETER	SYMBOL	RATINGS	UNIT
Applied Voltage	V_{MAX}	7.0	V
Power Dissipation Derate above 25°C	P_D	450 4.5	mW mW/°C
Operating Temperature	T_{OPR}	-25 ~ +75	°C
Storage Temperature	T_{STG}	-55 ~ +125	°C

Note: Absolute maximum ratings are those values beyond which the device could be permanently damaged. Absolute maximum ratings are stress ratings only and functional device operation is not implied.

■ RECOMMENDED OPERATING CONDITIONS (Ta=25°C)

PARAMETER	SYMBOL	MIN	TYP	MAX	UNIT
Power Supply Voltage	V_{CC}	2.8		6.5	V

■ ELECTRICAL CHARACTERISTICS (Ta=25°C, $V_{CC}=5.0V$, $R_L=32\Omega$, $V_{IN}=-6dBV$, $f=1kHz$)

PARAMETER	SYMBOL	CONDITIONS	MIN	TYP	MAX	UNIT
Mute Pin Control Voltage	V_{TM}		0.3	0.7	1.6	V
Quiescent Current	I_Q	$V_{IN}=0V_{rms}$	4	7	10	mA
Voltage Gain	G_v		4	6	8	dB
Voltage Gain Difference Between Channels	$\Delta G_{v(DIFF)}$		-0.5	0	0.5	dB
Total Harmonic Distortion	THD	BW=20~20kHz		0.02	0.1	%
Rated Output 1	P_{o1}	$R_L=32\Omega, THD<0.1\%$	25	31		mW
Rated Output 2	P_{o2}	$R_L=16\Omega, THD<0.1\%$	50	62		mW
Output Noise Voltage	eN	BW=20~20kHz, $R_g=0\Omega$		-93	-85	dBV
Channel Separation	CS	$R_g=0\Omega$	82	90		dB
Mute Attenuation	ATT	$R_g=0\Omega$	70	80		dB
Ripple Rejection	RR	$f_{RR}=100Hz, V_{RR}=-20dBV$	50	57		dB

MEASUREMENT CIRCUIT

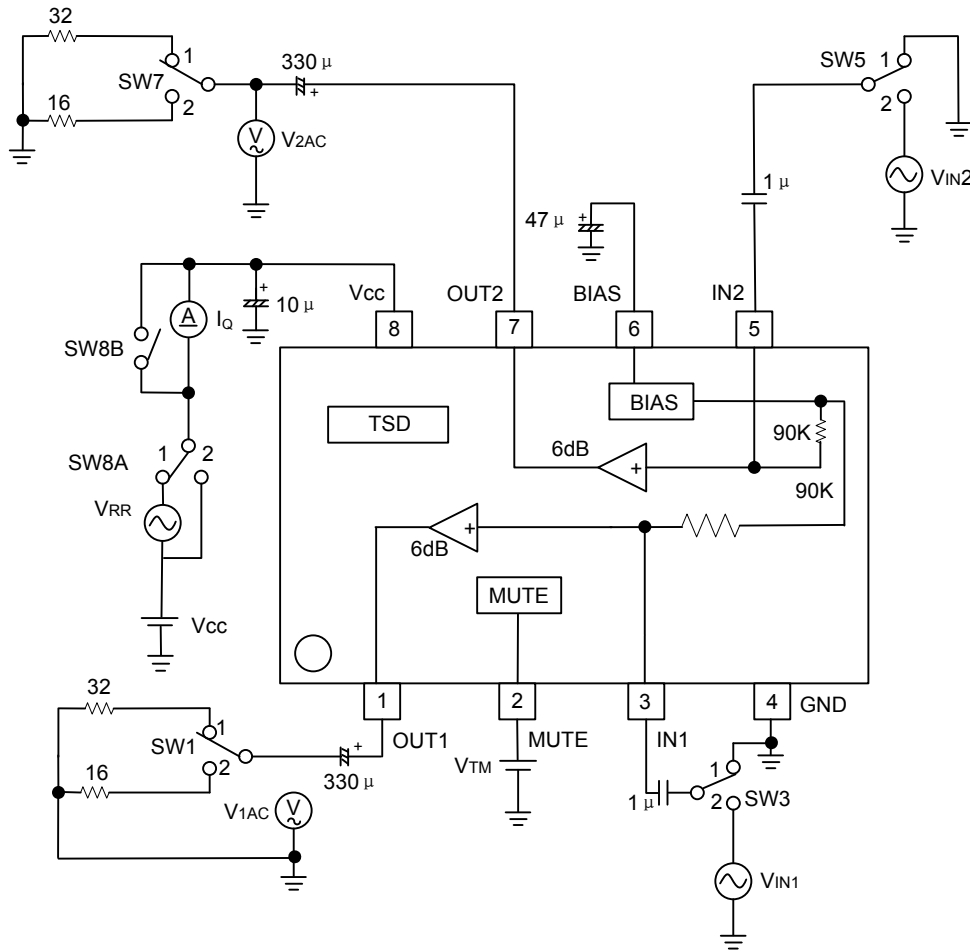

MEASUREMENT CONDITIONS

SIGNAL	SW TABLE						MONITOR	CONDITIONS
	SW1	SW3	SW5	SW7	SW8A	SW8B		
I_Q	1	1	1	1	2	OFF	I_Q	
V_{TM}								
G_{VC}	1	2	2	1	2	ON	V_{1AC}, V_{2AC}	$f=1kHz, V_{IN1/2}=-6dBV, V_{TM}=1.6V$
ΔG_{VC}								$G_{VC1} - G_{VC2}$
THD	1	2	2	1	2	ON	V_{1AC}, V_{2AC}	$f_{in}=1kHz, V_{IN1/2}=-6dBV, V_{TM}=1.6V$
P_{o1}	1	2	2	1	2	ON	V_{1AC}, V_{2AC}	$f_{in}=1kHz, V_{IN1/2}=-6dBV, V_{TM}=1.6V$
P_{o2}	2	2	2	2	2	ON	V_{1AC}, V_{2AC}	$f_{in}=1kHz, V_{IN1/2}=-6dBV, V_{TM}=1.6V$
V_{NO}	1	1	1	1	2	ON	V_{1AC}, V_{2AC}	
CS	1	1	2	1	2	ON	V_{1AC}, V_{2AC}	$f_{in}=1kHz, V_{IN2}=-6dBV, V_{TM}=1.6V$
	1	2	1	1	2	ON	V_{1AC}, V_{2AC}	$f_{in}=1kHz, V_{IN1}=-6dBV, V_{TM}=1.6V$
ATT	1	2	2	1	2	ON	V_{1AC}, V_{2AC}	$f_{in}=1kHz, V_{IN1/2}=-6dBV, V_{TM}=0.3VB$
RR	1	1	1	1	1	ON	V_{1AC}, V_{2AC}	$V_{RR}=-20dBV, f_{RR}=100Hz$

■ CIRCUIT OPERATION

Rising edge timing

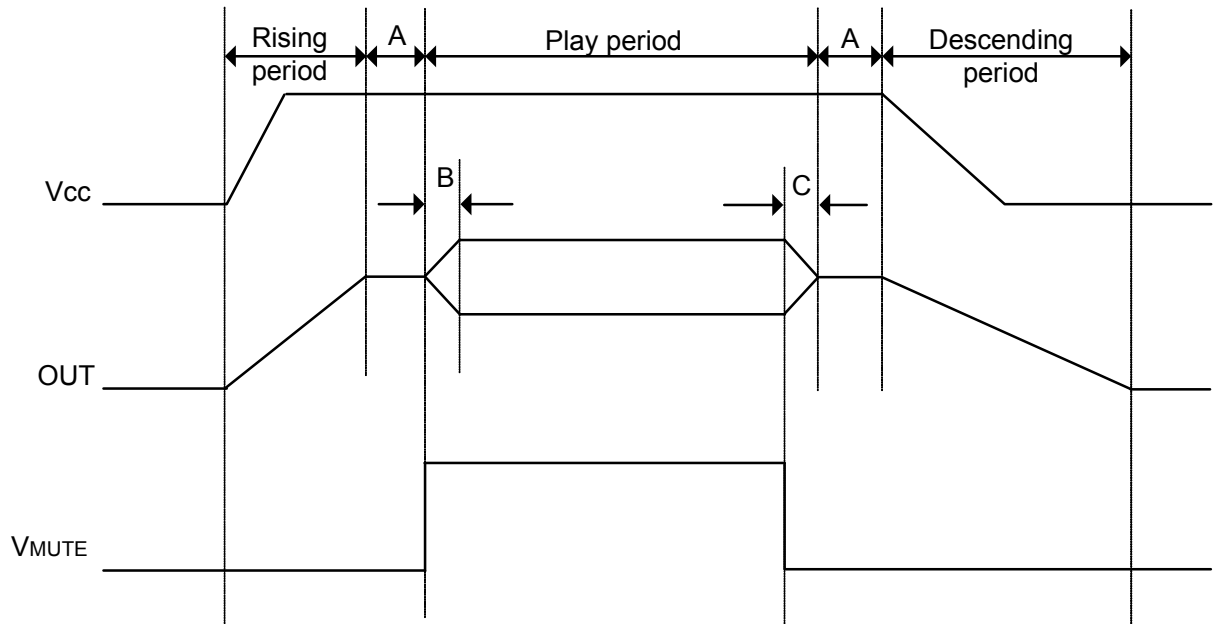

A: MUTE period(use with MUTE=Low to prevent the popping noise when the power is turned on and off).

B: MUTE release time(used to prevent the popping noise at the release of MUTE with the external C 2 and R2 and therefore possesses a time constant ,so be careful of the timing).

C: MUTE start time(also possesses a time constant like the MUTE release time).

APPLICATION EXAMPLE

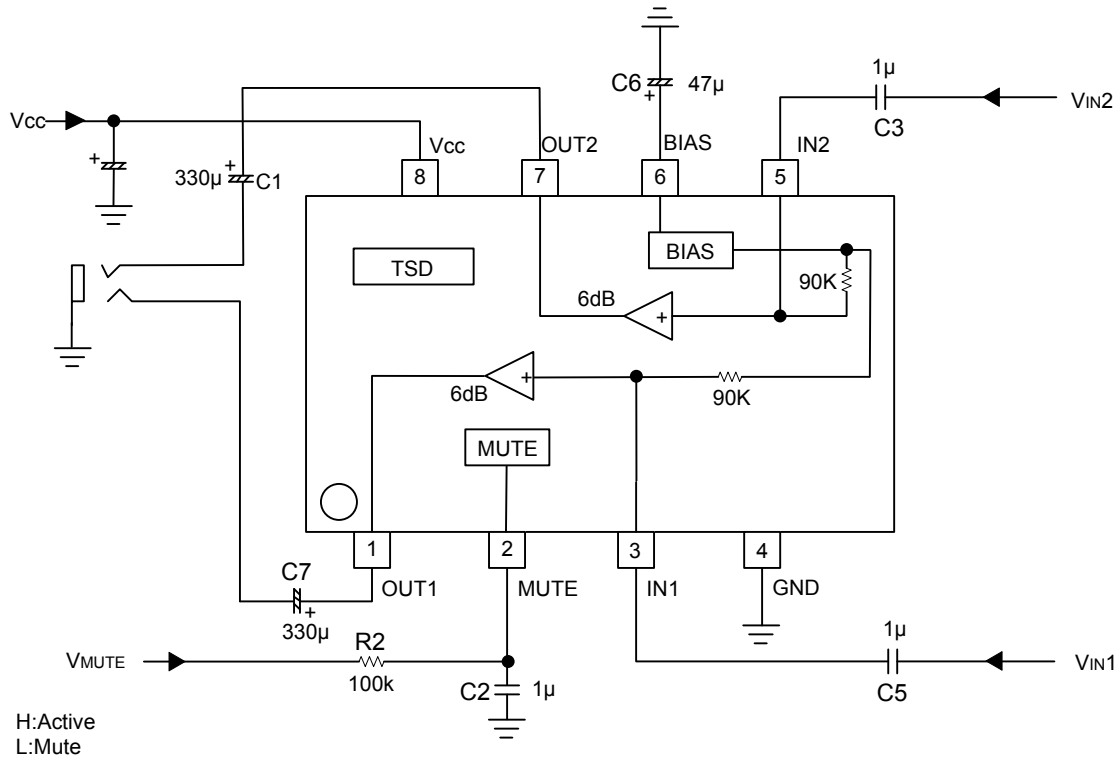

EXPLANATION OF EXTERNAL COMPONENTS

(1)Input coupling capacitor (C3 and C5)

First determined by the low-band cut-off frequency. Because the input impedance is 180kΩ for this IC, it can be determined by this formula

$$C3(C5)=1/(2\pi \times 180k\Omega \times f)$$

But make sure taking the fluctuations, ambient temperature, etc into consideration. A multi-layered ceramic capacitor is recommended.

(2)BIAS capacitor(C6)

47µF when Vcc=5V, and 33µF when Vcc=3V. Before changing these values take the sufficient considerations. It is because the electrical characteristics will be adversely affected and popping noise may occur if the capacitance is lowered too much.

(3)MUTE pin for anti-pop measures (R2 and C2)

An impedance of 190kΩ must be possessed with respect to GND, so the MUTE mode may become unable to be released if R2 is increased too much.

(4)Output coupling capacitor(C1 and C7)

Also determined by the low-band cutoff frequency. Like the output load resistance value R_L (a resistor R_x will be inserted, assuming that for output protection or current limiting), it can be calculated by this formula

$$C1(C7)=1/(2\pi \times (R_L + R_x) \times f)$$

(5)Input gain adjustment resistor(R3 and R4)

External resistors R3 and R4 can perform input gain adjustment. The desired gain can be calculated by this formula

$$G_v=6+20\log(90k\Omega/(90k\Omega+R3))[dB]$$

■ TYPICAL CHARACTERISTICS

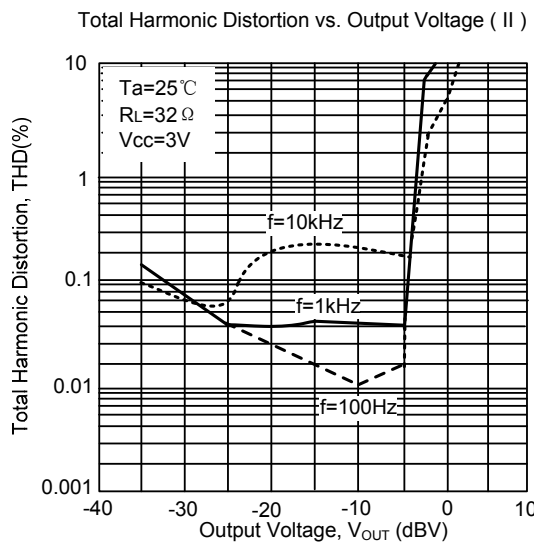
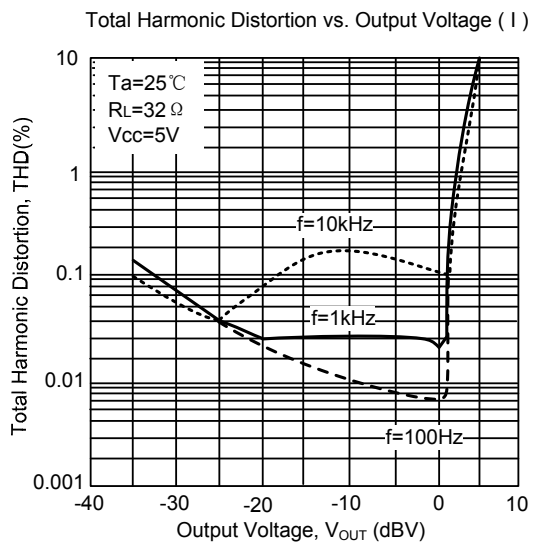
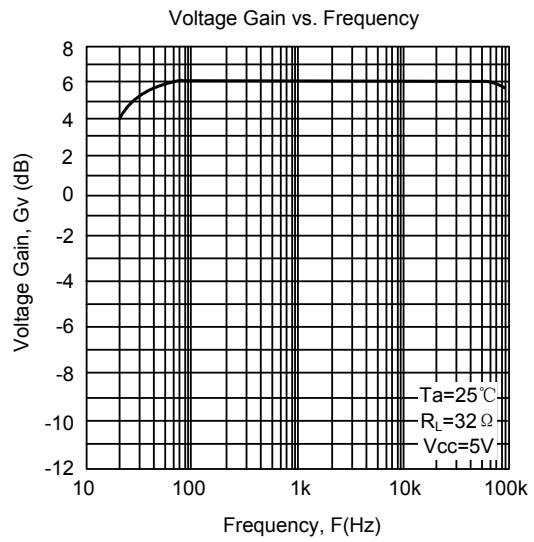
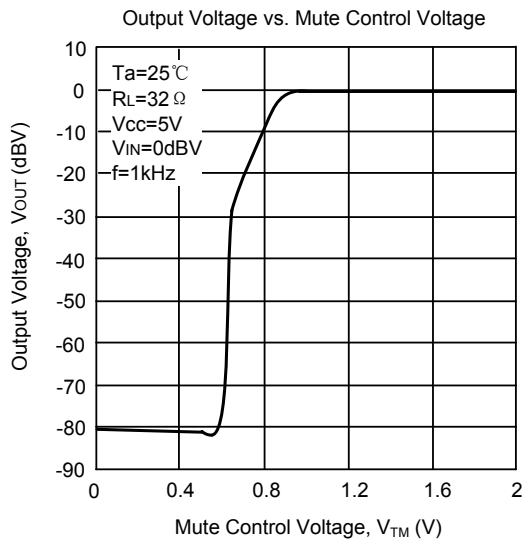
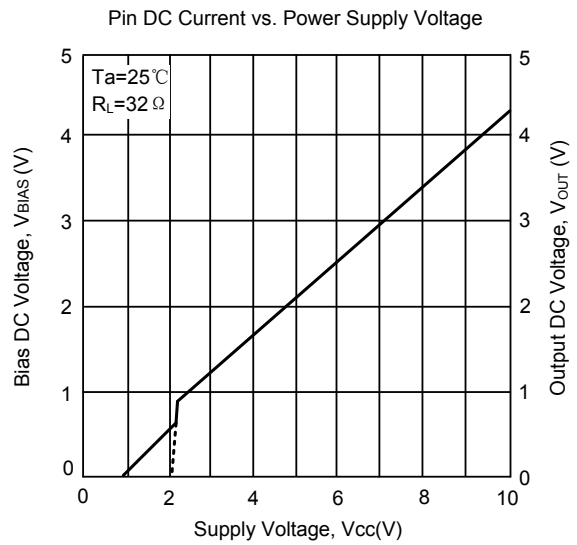
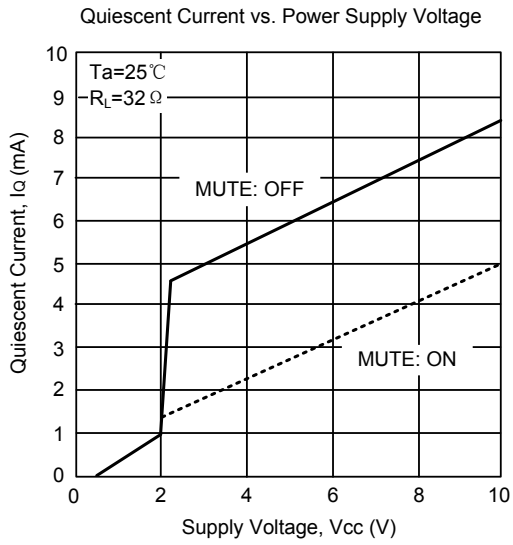

■ TYPICAL CHARACTERISTICS(Cont.)

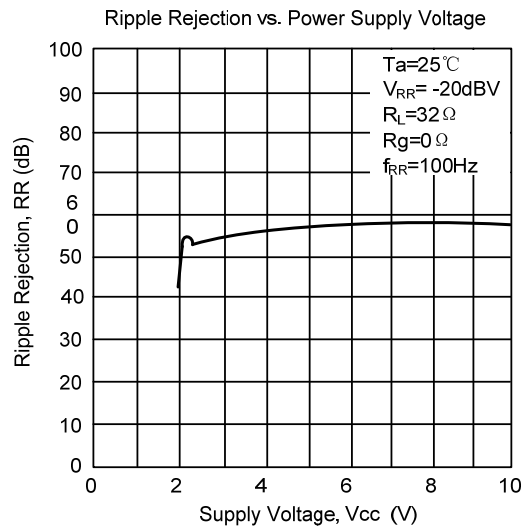
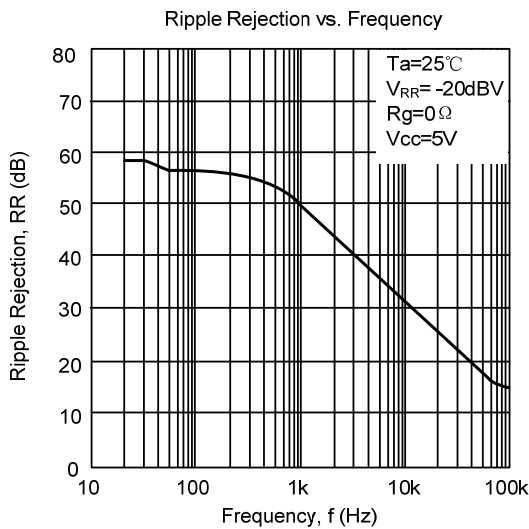
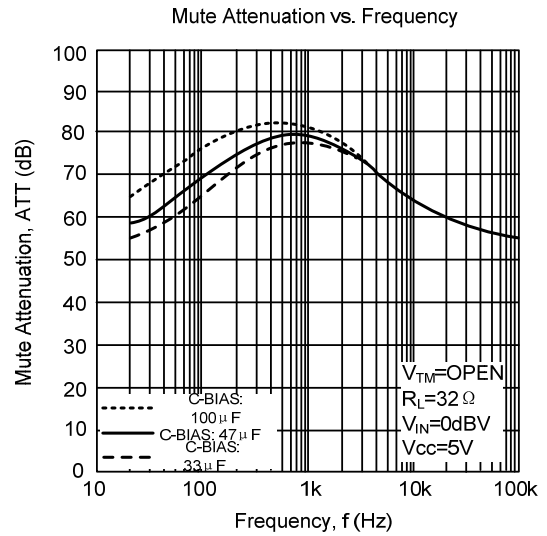
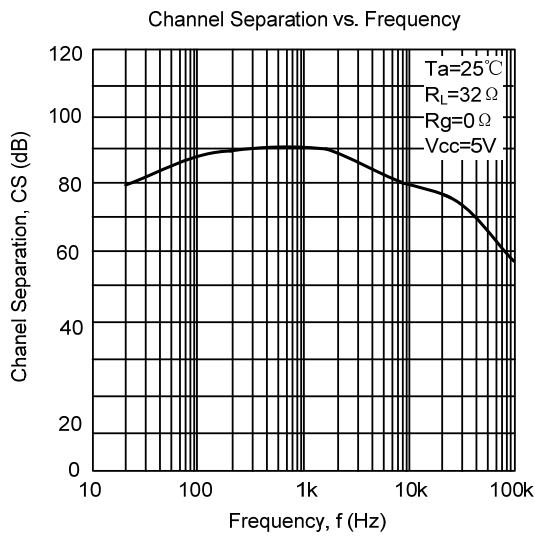
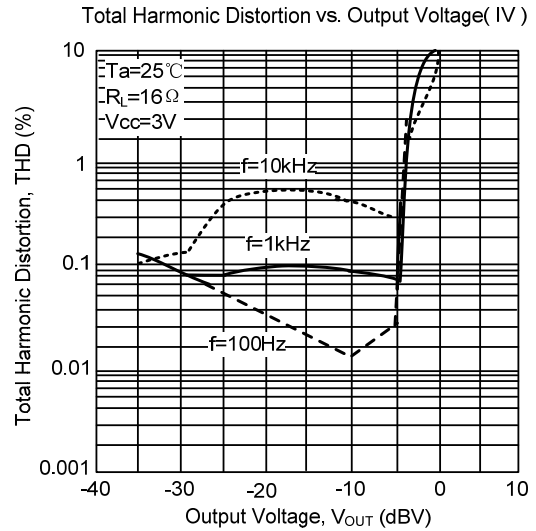
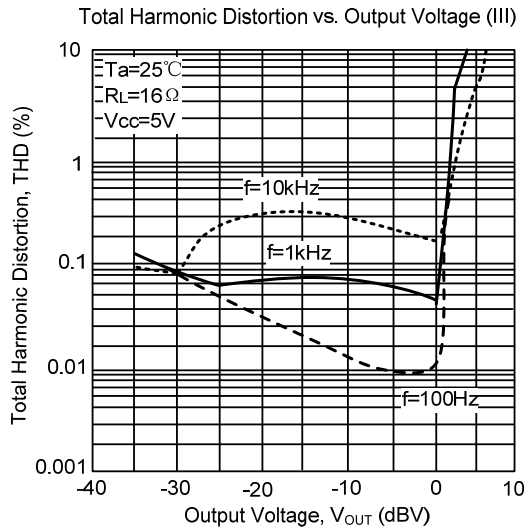

UTC assumes no responsibility for equipment failures that result from using products at values that exceed, even momentarily, rated values (such as maximum ratings, operating condition ranges, or other parameters) listed in products specifications of any and all UTC products described or contained herein. UTC products are not designed for use in life support appliances, devices or systems where malfunction of these products can be reasonably expected to result in personal injury. Reproduction in whole or in part is prohibited without the prior written consent of the copyright owner. The information presented in this document does not form part of any quotation or contract, is believed to be accurate and reliable and may be changed without notice.